

# The Digital Data Chain Overview

THTH autumn webinar  
Location: online  
November 15<sup>th</sup> 2023

Christoph Attila Kun, BASF SE



Chempark Dormagen (source: BAYER AG)



BASF Verbund Site Ludwigshafen (source: BASF SE)

... is an asset intensiv industry

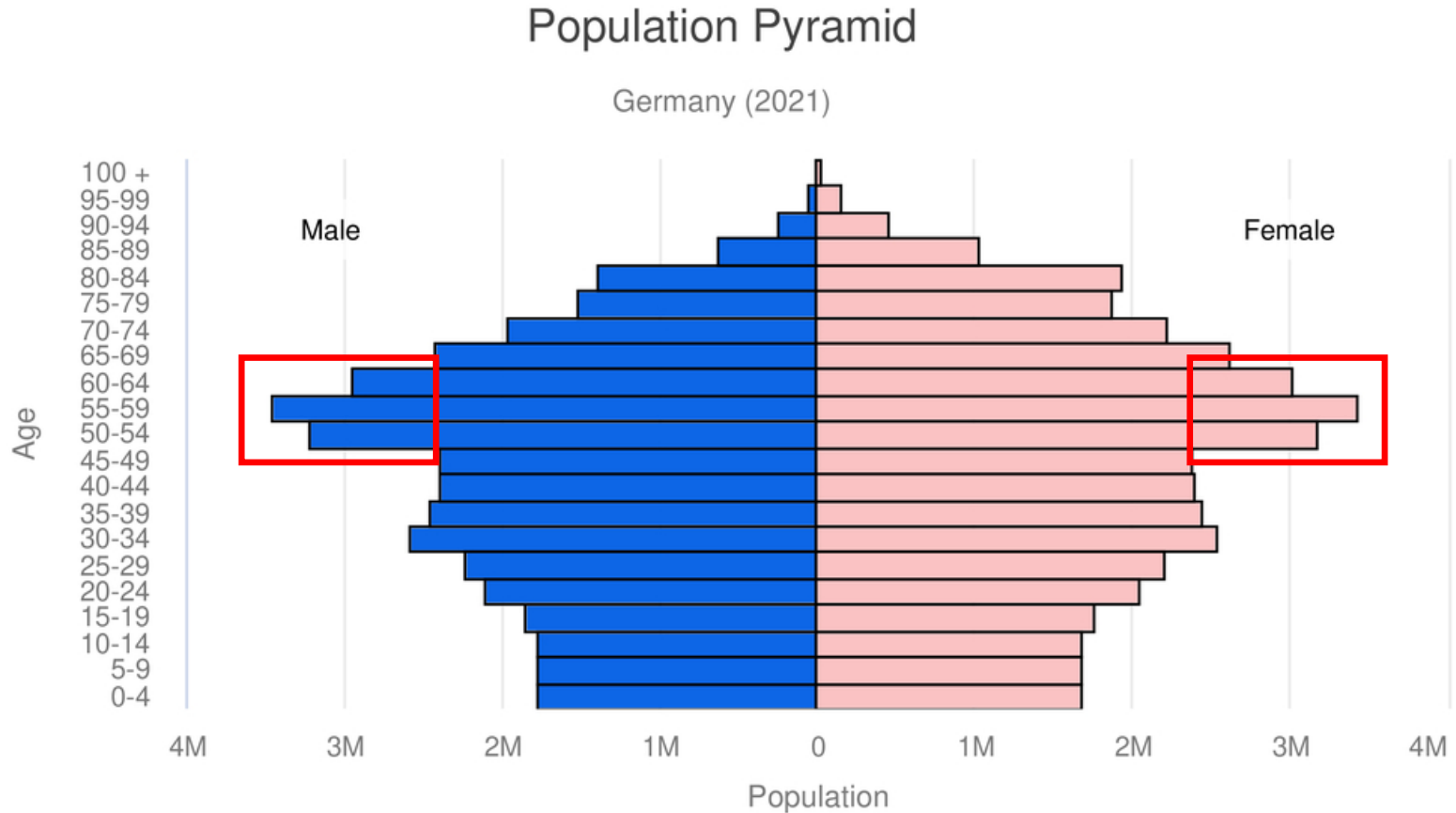

U.S. Census Bureau, International Data Base

Over the next decade, a double-digit percentage of workforce will leave the labour market, without being replaced. In order to maintain Europe's prosperity and economic strength, it is essential to automate all processes that can be automated. We can no longer afford to waste our employees' time searching for information.

# Simplified data model of a Digital Twin

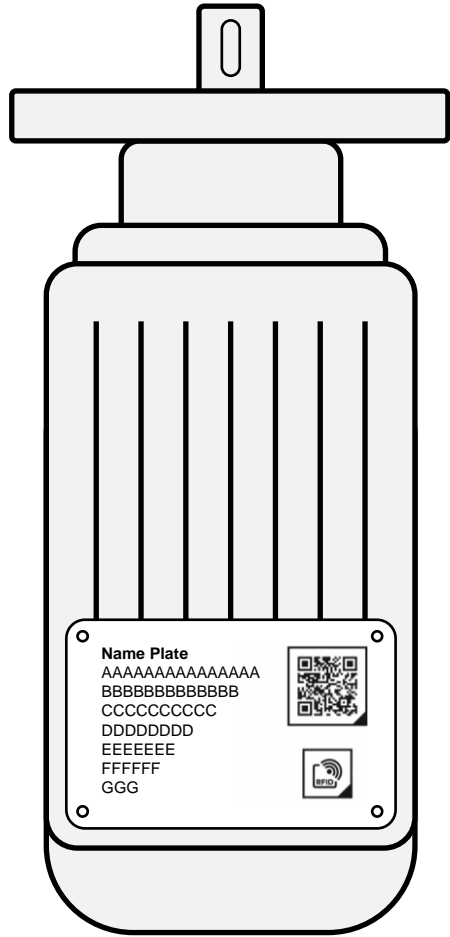

**physical object**

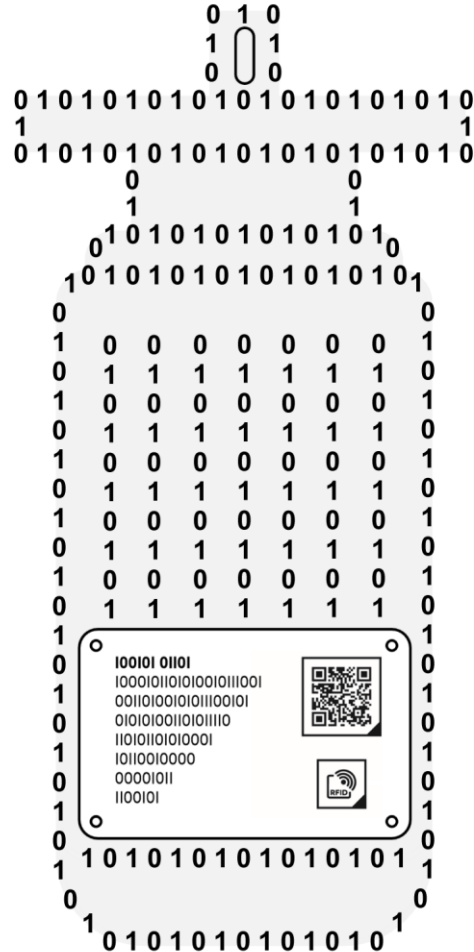

**digital twin**  
*digital representation of the physical object*

**functional model**

- simulation
- prediction
- condition monitoring
- ...



**information model**

- tech specs
- documentation
- life cycle information
- ...

## ECODESIGN FOR SUSTAINABLE PRODUCT REGULATION (ESPR) OF THE EU COMMISSION

### Article 8: Digital Product Passport

Compulsory for all products to be put in the European market.

Minimum content and structure requirements set by ESPR.  
Additional requirements to be set by delegated acts.

#### Objectives:

- ensure that actors along the value chain [...] can access product information relevant to them;
- facilitate the verification of product compliance by competent national authorities; and
- improve traceability of products along the value chain.

# The DIGITAL DATA CHAIN → Combining the technologies

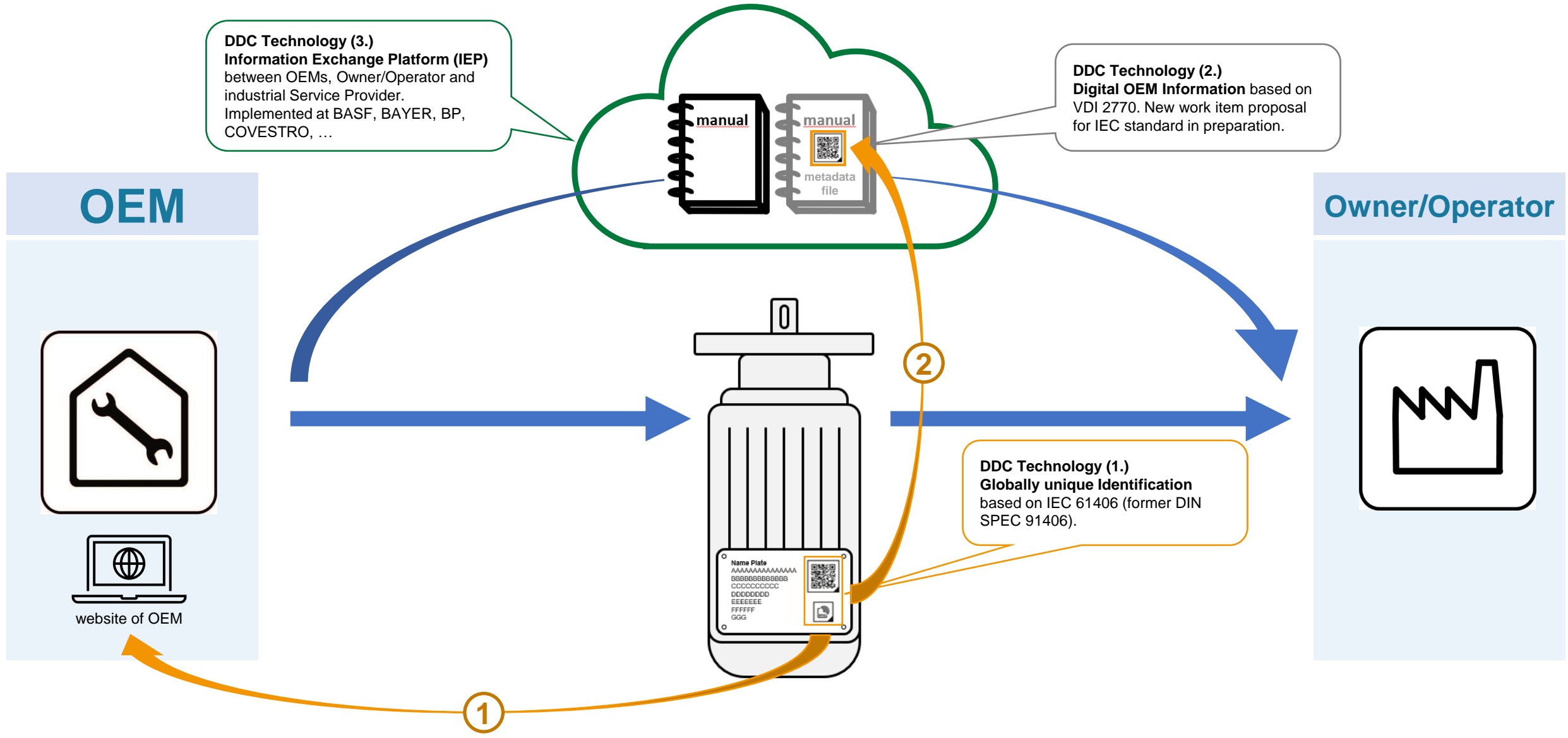



# The Digital Data Chain Consortium



## Mission & Vision

- foster the spread of the 3 DDC technologies,
- achieve international standardization at ISO/IEC, as *must* for global acceptance by operators, suppliers and engineering contractors,
- have the critical mass to create the momentum for growth of the digital ecosystem.

Within 10 months more than 50 Companies have joined the Consortium:



BASF is the elected Consortium Leader of the Digital Data Chain Consortium (DDCC) → [www.digitaldatachain.com](http://www.digitaldatachain.com)

# IEC 61406 – Identification Link → connecting the physical product to its Digital Twin

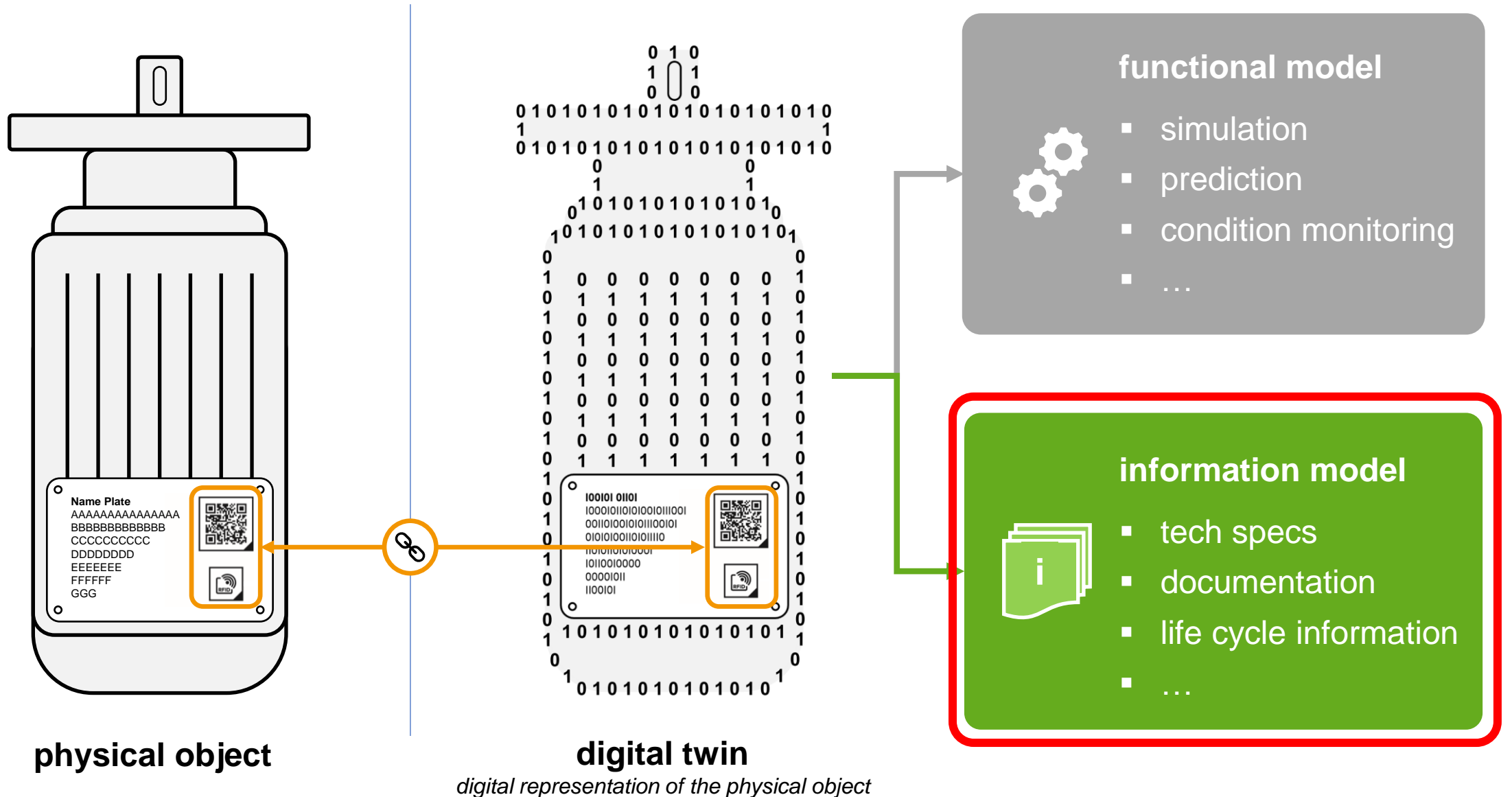



## Identification of an individual

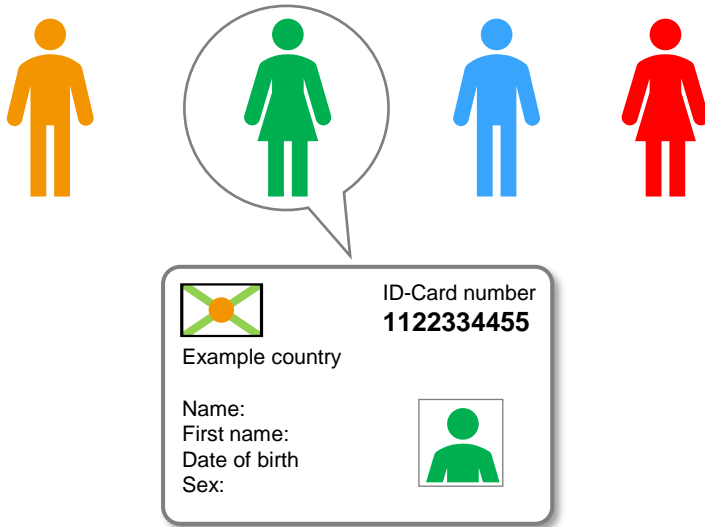

## Identification of an individual

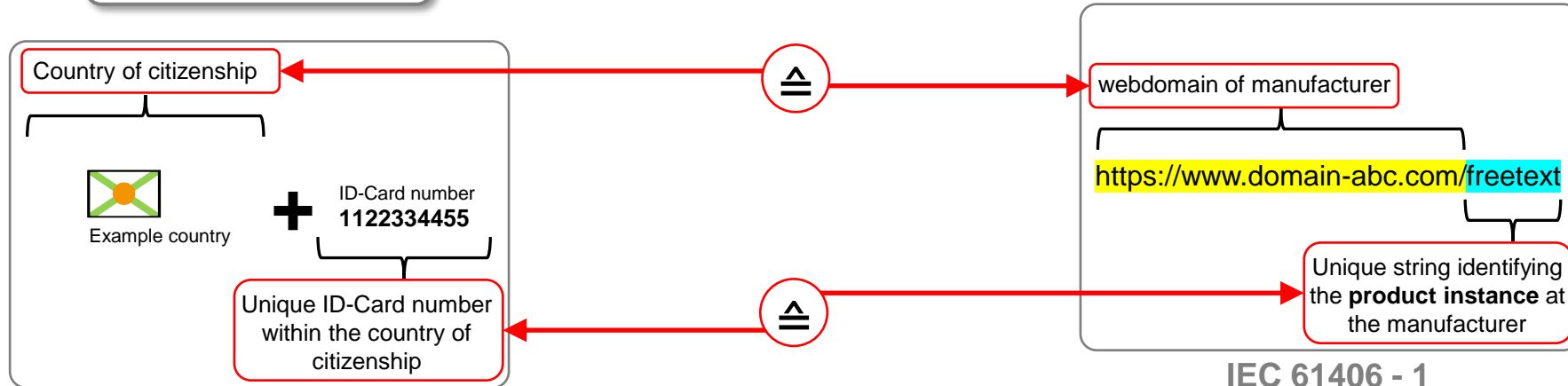

## Identification of an individuum

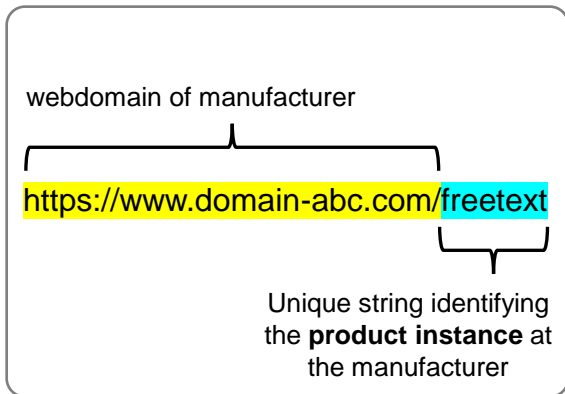
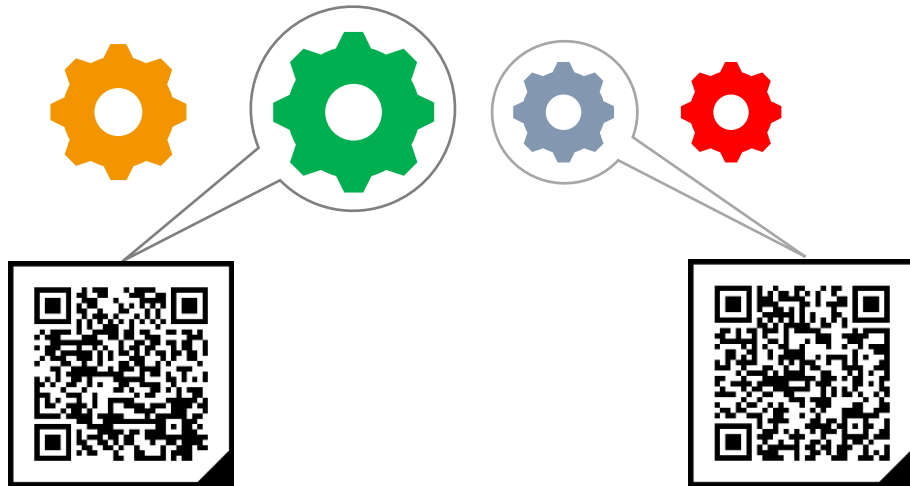

IEC 61406 - 1

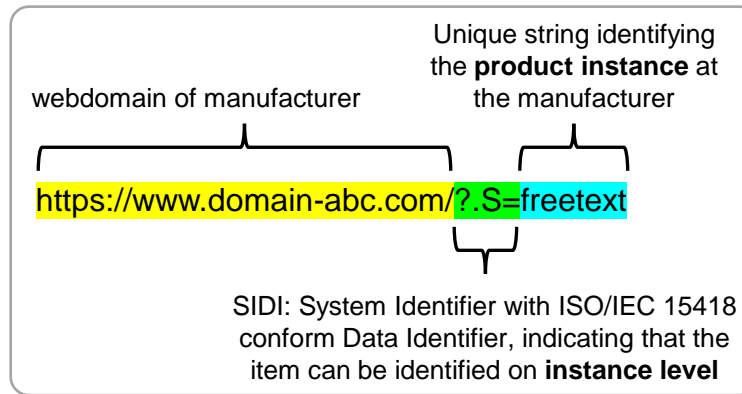

IEC 61406 - 2

## Identification of an identic group

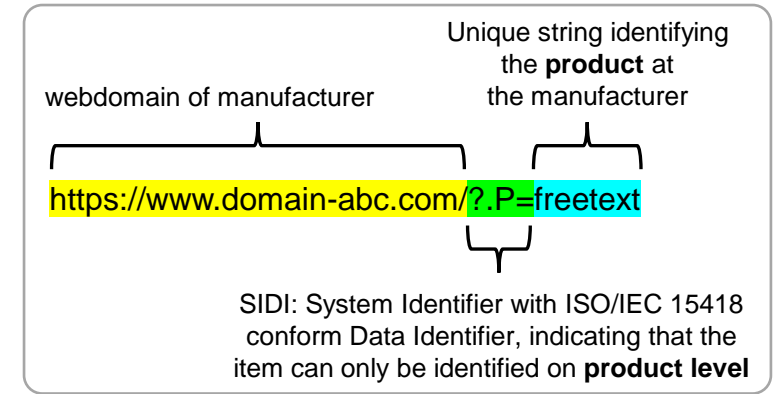
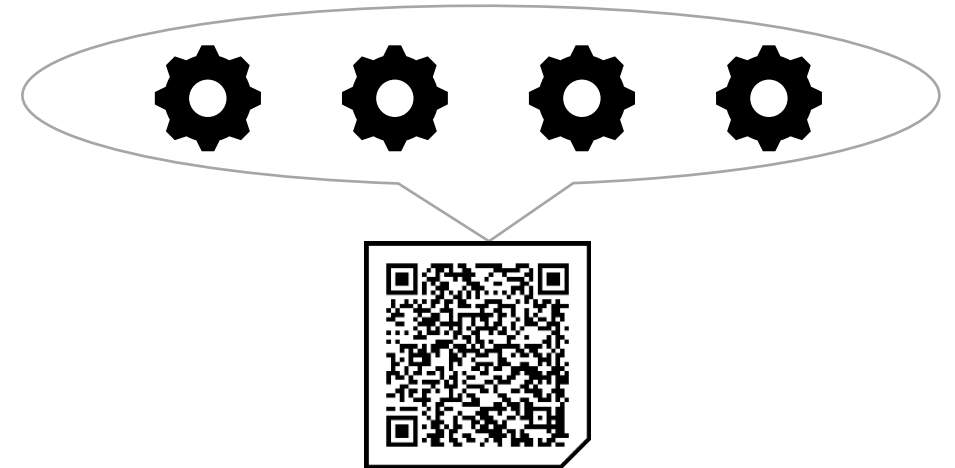

IEC 61406 - 2

# IEC 61406 – series the fully interoperable ID solution

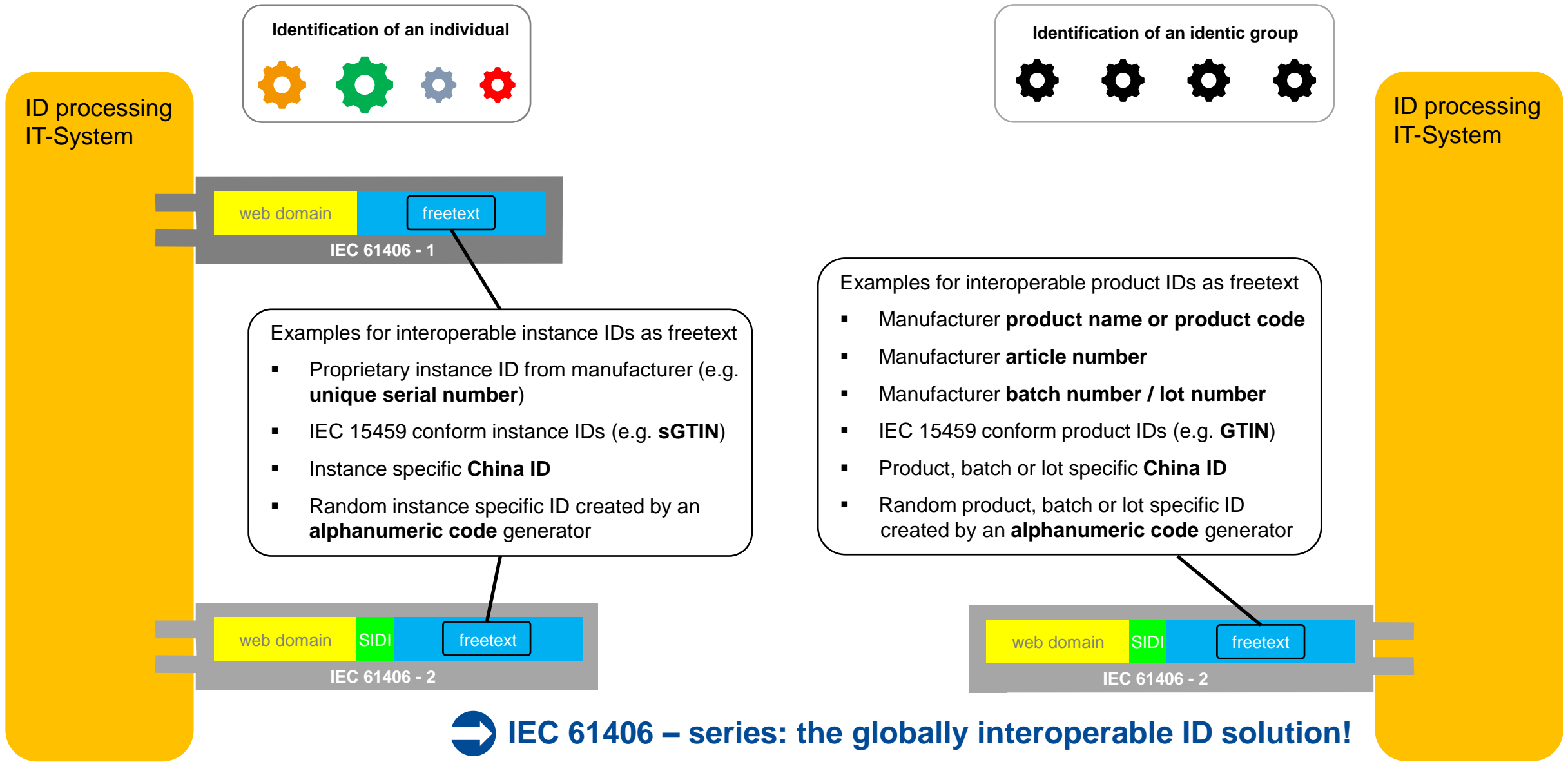

**IEC 61406 – series: the globally interoperable ID solution!**

# The DIGITAL DATA CHAIN → Combining the technologies

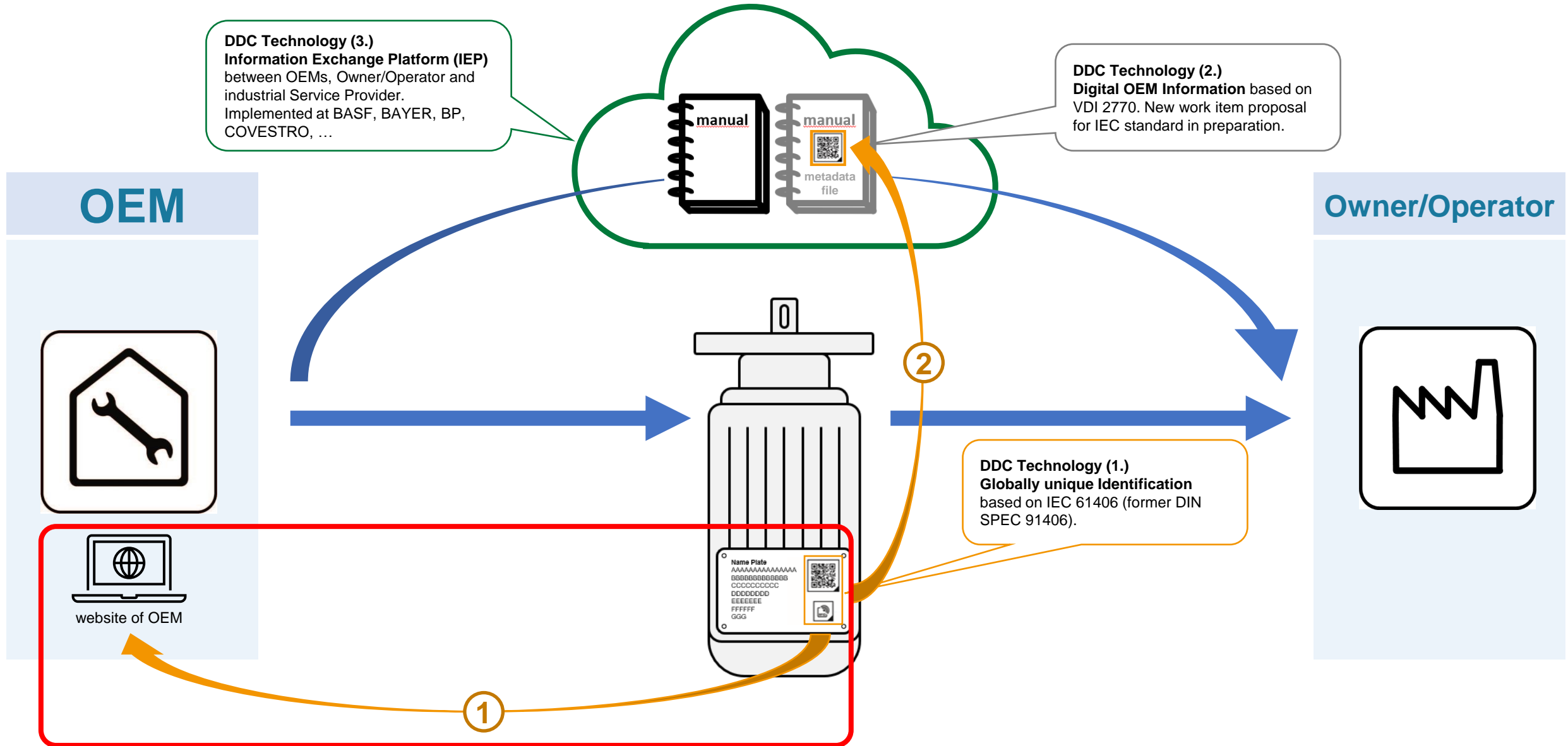

# Live Demo: Example Siemens

Product



ID Link

i.siemens.com >

Package



Online Digital Nameplate

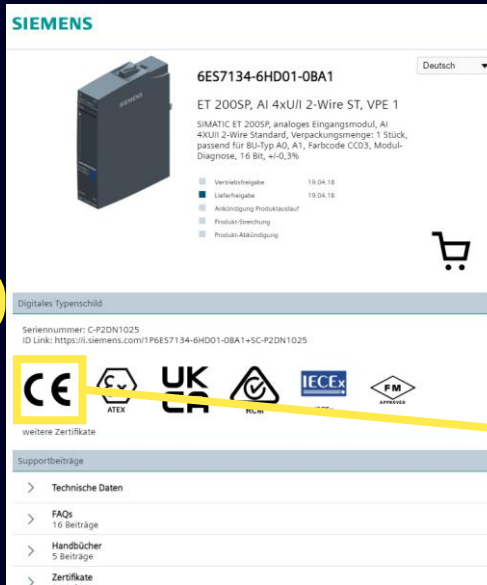

Online Declaration of Conformity

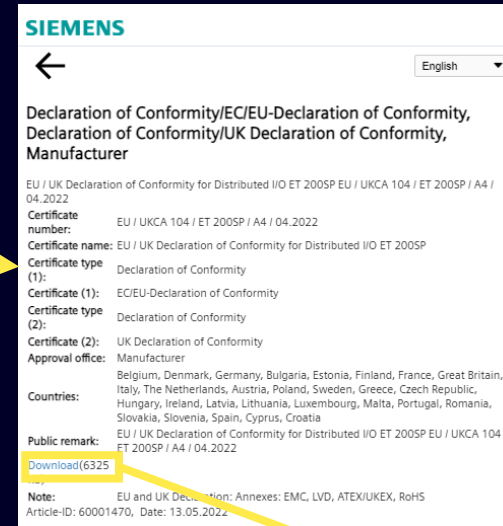

Download



PDF of original Dec. of Conf.

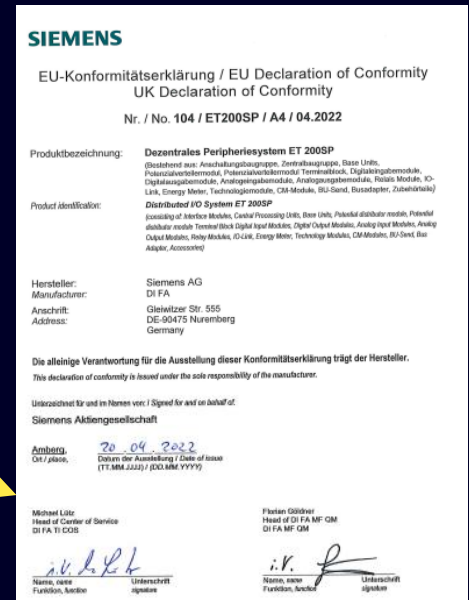

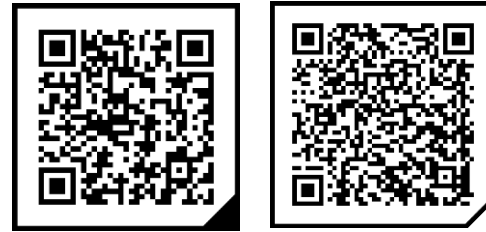

## Advantages of IEC 61406-series\* ID Link

- ✓ Developed from the industry for the industry, without any protected IP-rights, vendor lock in or risk of a monopol/oligopol
- ✓ Based on an URL, the worldwide most frequently used ID (>20 billions per day)
- ✓ **100% cost free**, if your company has its own website/webdomain
- ✓ **100% interoperable** with any legacy ID-system → **key requirement of EU Commission for DPP system!**
- ✓ 100% support of the principle „The ID is just an ID, the content has to be in the backend“





classical, „non intelligent“  
documentation provisioning

Customer Project ID	LDPE/2021/NA/34-56
Purchase Order nr.	PO-9876-5432
Purchase Order item nr.	32
Engineering Tag nr.	B123-4564-6543
Equi ID or Material nr.	81726354

Filename

AM-6kvum.pdf

AM-6kvac.pdf

AM-6kvmm.pdf

AM-6kvsp.pdf  
AM-6kvsp.xlsx

AM-6kvss.pdf  
AM-6kvss.xlsx



VDI 2770 conform „intelligent“ documentation provisioning

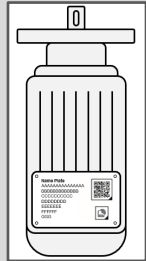

Manufacturer	Test Company AG
Producttype	Asynchron motor
Order Code	AM-6kv-4321
Serialnumber	5678-F
IEC 61406 ID	Test-company.ch/AM-6kv-4321/5678-F

Customer Project ID	LDPE/2021/NA/34-56
Purchase Order nr.	PO-9876-5432
Purchase Order item nr.	32
Engineering Tag nr.	B123-4564-6543
Equi ID or Material nr.	81726354

Filename	Title	description	keywords	document ID	VDI 2770 classification	IEC 61355 classification	language
AM-6kvum.pdf	manual	user manual	operation, use, start up,	Um-AM-6kv-4321-2021-FA	03-02 Operation	DC	EN
AM-6kvac.pdf	Ex-certificate	ATEX-certificate	explosion prevention	Ac-AM-6kv-4321-2021-FA	02-04 Certificates	QC	EN, DE, FR
AM-6kvmm.pdf	maintenance manual	Inspection & maintenance manual	inspection, maintenance,	Ac-AM-6kv-4321-2021-FA	03-04 Inspection, maintenance	DC	EN
AM-6kvsp.pdf AM-6kvsp.xlsx	spare parts	spare part list	casing, fan, shaft, bearing	Ac-AM-6kv-4321-2021-FA	03-06 Spare parts	PB	EN
AM-6kvss.pdf AM-6kvss.xlsx	spec-sheet	technical specification sheet	power, torque	Ss-AM-6kv-4321-2021-FA	02-01 Technical specification	EC	EN

# Digital Data Chain (DDC) technologies → the Information Exchange Platform (IEP)

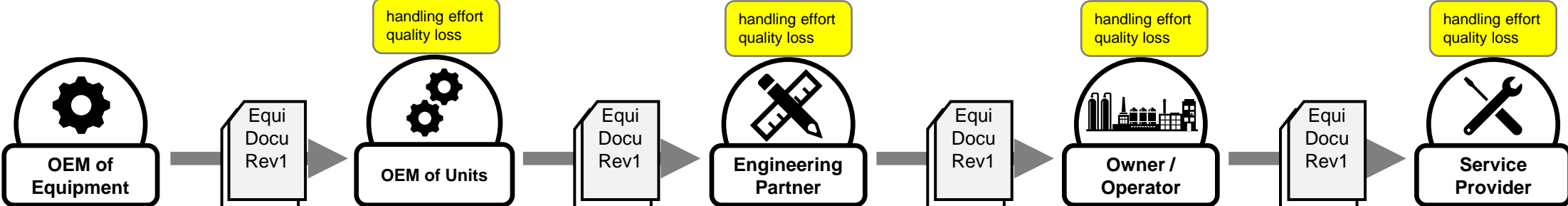

classical, „non intelligent“  
documentation provisioning

# Digital Data Chain (DDC) technologies → the Information Exchange Platform (IEP)

## Lifecycle

Engineering Phase  
(Greenfield)

Operations & Maintenance  
Phase  
(Brownfield)

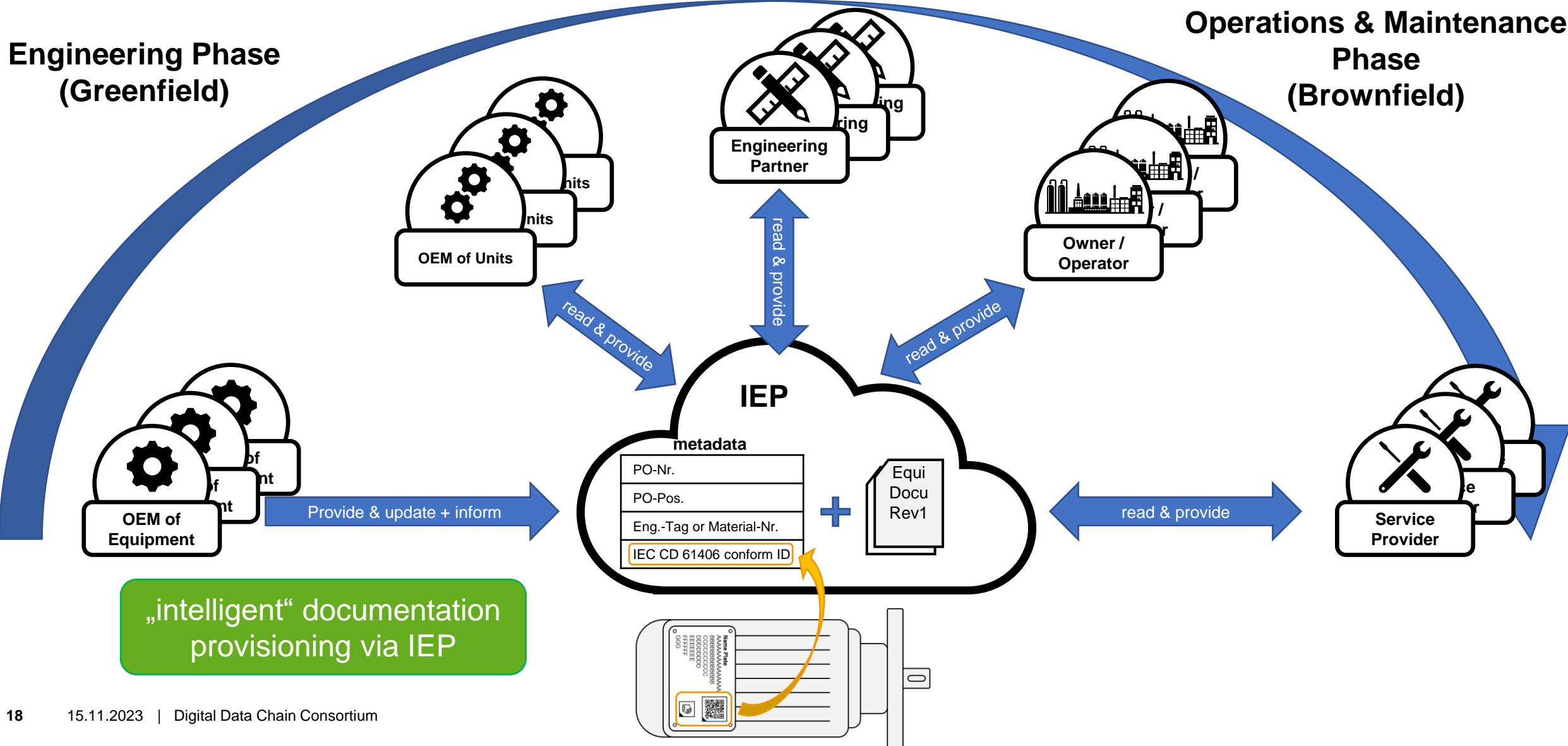

# The DIGITAL DATA CHAIN → Combining the technologies

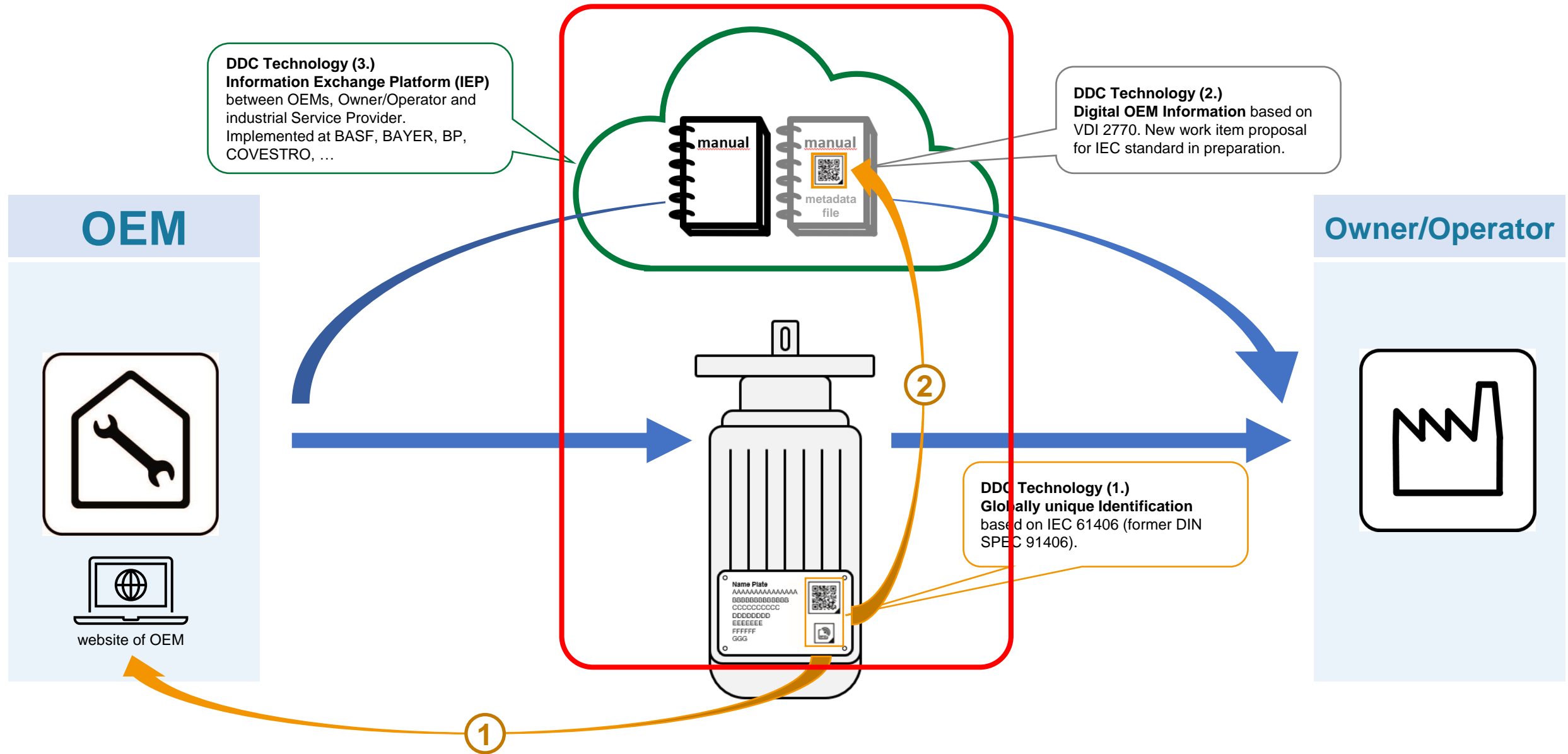

## Sharecat Information Exchange Platform

**Radar sensor for continuous level measurement of liquids and bulk solids**

Verification status

i

★
🔔<sup>2</sup>
👤
⋮

Revision #1 ▾  
In construction

Serial Number  
58655705

Description  
All-round radar measuring device

Class  
Radar sensor

Info Classification  
Confidential (Restricted)

🔒
✔ Draft

✔ Under review

✔ Released

4 Superceded

MARK AS VOID

**Detailed Information**

**Instance Information**

**Production Date\***  
2022

**Batch Number\***

**Company Specification**  
VEGAPULS 6X

**Design Codes**

**Product Information**

**Model ID\***  
VEGAPULS 6X

**Product Description**  
Radar sensor for continuous level measurement of liquids and bulk solids

**Manufacturer**  
VEGA

**Photos**

**Documents & Files**

Document Category	Document Id	Title	File Name	Manufacturer	Description	Key Words	Language	Valid From	Status
Technical specification	695_DE_Technische_Spezifikation	Technische Spezifikation	📄 02-01_Technis...	VEGA Grieshaber KG	VDI-2770 gebundenes Paket für technische Spezifikationen	VEGA; VEGAPULS 6X; radar	de		Released
Technical specification	697_EN_Technical_specification	Technical specification	📄 02-01_Technic...	VEGA Grieshaber KG	VDI-2770 wrapped package for technical specification	VEGA; VEGAPULS 6X; radar	en		Released



## SAP Business Network for Asset Collaboration

SAP Equipment

37000000 / 37010000 / LESER 433 - SAFETY VALVE /

LESER 433 - SAFETY VALVE 10136145

Manage ☆ 📦 ⚙️ 🔗

Manufacturer: LESER ID Link Shared By: 1 Partners Functional Location: E60 External IDs Status: Published Languages: EN

INFORMATION ▼ STRUCTURE & PARTS ▼ **DOCUMENTATION** ▼ MAINTENANCE & SERVICE ▼ TIMELINE

Documents

All (16) Equipment (7) Models (9) Locations (0) Tagged Images (0)  🔍 Download ↕️ ☰ 🔍

<input type="checkbox"/>	Document	File Name	File Type	Confidentiality	Phase	Category	Language	Source	File Size	From	Changed On
<input type="checkbox"/>	<b>Abnahmedokument</b> D.POCOPE.7	<a href="#">Abnahmedokument_Dummy.pdf</a> <a href="#">More</a>	PDF		Acquisition	Others	German	SAP PoC Operator	7 KB		2021-07-01
<input type="checkbox"/>	<b>Zeichnung</b> D.POCOPE.9	<a href="#">Zeichnung_Dummy.pdf</a> <a href="#">More</a>	PDF		Design / Installation	Drawings/Schemes	German	SAP PoC Operator	7 KB		2021-07-01
<input type="checkbox"/>	<b>Zertifikat</b> D.POCOPE.4	<a href="#">10259764_Cert_10956330_DE.pdf</a> <a href="#">More</a>	PDF		Operation	Certificates	German	SAP PoC Operator	447 KB		2021-07-01
	<b>Bestellung</b>	<a href="#">02 BASF</a>									



# DIGITAL DATA CHAIN → relation to other standards and technologies

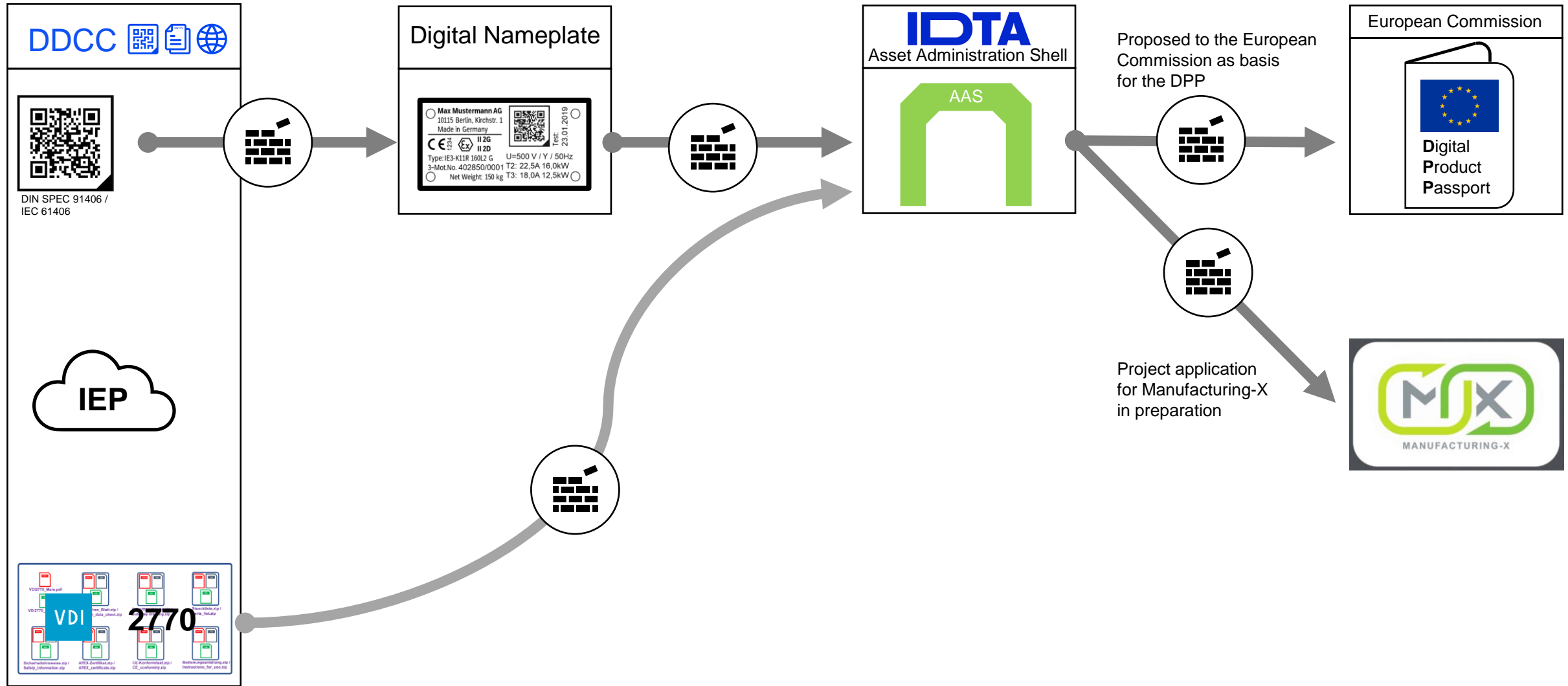

building block for

Will AI replace the Digital Twin?

No, the Digital Twin will provide the authenticated and reliable information to be processed by AI!



**Christoph Attila Kun**

Global Product Manager *Digital Data Chain* @ BASF  
Manager *Digital Data Chain Consortium Gbr* → [www.digitaldatachain.com](http://www.digitaldatachain.com)  
Chairman *VDI Experts Council 2770*

Mobil : +49 1522 8866364  
Mail: christoph-attila.kun@basf.com

Please don't hesitate to contact us, if you are interested in the Digital Data Chain (DDC) and its global implementation!



# Digital Data Chain Consortium

[www.digitaldatachain.com](http://www.digitaldatachain.com)